

# INNOVATIVE CONSTRUCTION CHEMISTRY





Bronco Buildsmart LLP since its inception has established a name for itself in the construction industry with a wide range of proven and time-tested products. With a special focus on quality, technology and most of all developing long term relationships with clients, the organization has developed a track record of excellence.

Bronco has a wide product range of construction chemicals that are cost efficient, environment friendly and one that adds significant value to any infrastructure project. While Bronco is headquartered in the enterprising city of Ahmedabad, Gujarat, India, the organization has nurtured relationships with clients across the country and it has also embarked on a global journey.

We are ISO 9001:2015 certified company with the most efficient Quality management system. Bronco aims to leverage the immense potential of cutting-edge research & technology to develop the highest quality products for the construction industry. Currently, manufactured at 2 modern facilities in Gujarat, the construction chemicals provided by Bronco are developed to

provide maximum utility to customers while causing minimal environmental impact. At Bronco, we are sincerely committed to the goal of sustainable development for a Greener tomorrow.

Our channel partner network goes wide and deep and runs across the nation, making Bronco products a preferred and trustworthy name when it comes to anything related to the construction industry. Over the years, we have left an indelible impact in the areas of Green Building Products, Construction Chemicals and Waterproofing Systems.

**Product Range:**

Our product range built on the backdrop of quality and ecological sensitivity can be identified in following broad categories:

- Ready Mix Plasters
- Adhesives - Precast, Tile & Stone
- Concrete Admixtures
- Waterproofing Membranes & Admixtures
- Repair & Rehabilitation
- Industrial Flooring & Sealants
- Insulation



## THE BRONCO DIFFERENCE

**Experienced Team**

Having been an active part of this industry for over three decades Bronco has cultivated a rich experience helping gain a significant advantage. Our team has worked on residential, commercial, industrial & infrastructure projects across various parts of the country. Every member on the team brings in unmatched experience and unique expertise that gives us unassailable edge over competition

**Research Driven**

We strongly understand the importance of research & development. R&D at Bronco is not only intense and detailed but also the Top Priority to remain ahead in a fiercely competitive environment. We work constantly to improve & innovate our product range.

Team Bronco has major focus on servicing customers with its rich experience and unique expertise also in effect reducing the environmental impact of the construction industry.

**Customer Centric**

We believe that every customer has a unique identity and have their specific product requirements and we at Bronco strive to fulfill those needs. Our team is available for technical support at construction sites. Our relationships with customers help us understand their needs better and develop even more effective solutions to suit their requirements.

**Sustainability**

With a commitment to sustainable development and a world where nature and infrastructure can peacefully co-exist. We lay special emphasis on minimizing environmental impact by monitoring product life cycle. All our products are formulated using consciously selected raw materials. Our products reduce the use of scarce resources on construction sites. To exemplify our commitment to the environment we are members of the Indian Green Building Council (IGBC).

### OUR SOLUTIONS FOR YOUR CONSTRUCTION



## PROTECT YOUR STRUCTURE & TAKE CARE OF YOUR STRUCTURE

### WATERPROOFING

**BRONCO® CEMSHIELD PU 1K:** Highly flexible, single component, moisture cure, pure polyurethane protective coating

**BRONCO® CEMGUARD PLUS:** High performance elastomeric cementitious waterproofing coating

**BRONCO® CEMCRYSTAL PLUS:** Cementitious waterproofing system which protects and waterproofs concrete structures by crystallization

**BRONCO® CEMGUARD KRYL:** Acrylic polymer based elastomeric heavy duty waterproof coating

### TECHNICAL MORTARS & GROUTS

**BRONCO® CEMGROUT POXY 21LV:** Low viscosity solvent free high strength fast cure injectable epoxy grout

**BRONCO® CEMREPAIR MC:** Single component general purpose pre-mixed flowable micro concrete

**BRONCO® CEMREPAIR PMC:** Polymer modified fibre reinforced concrete repair mortar

**BRONCO® CEMGROUT SP75:** Non-shrink, high early strength, chloride free, ready to use cementitious free flow anchor grout

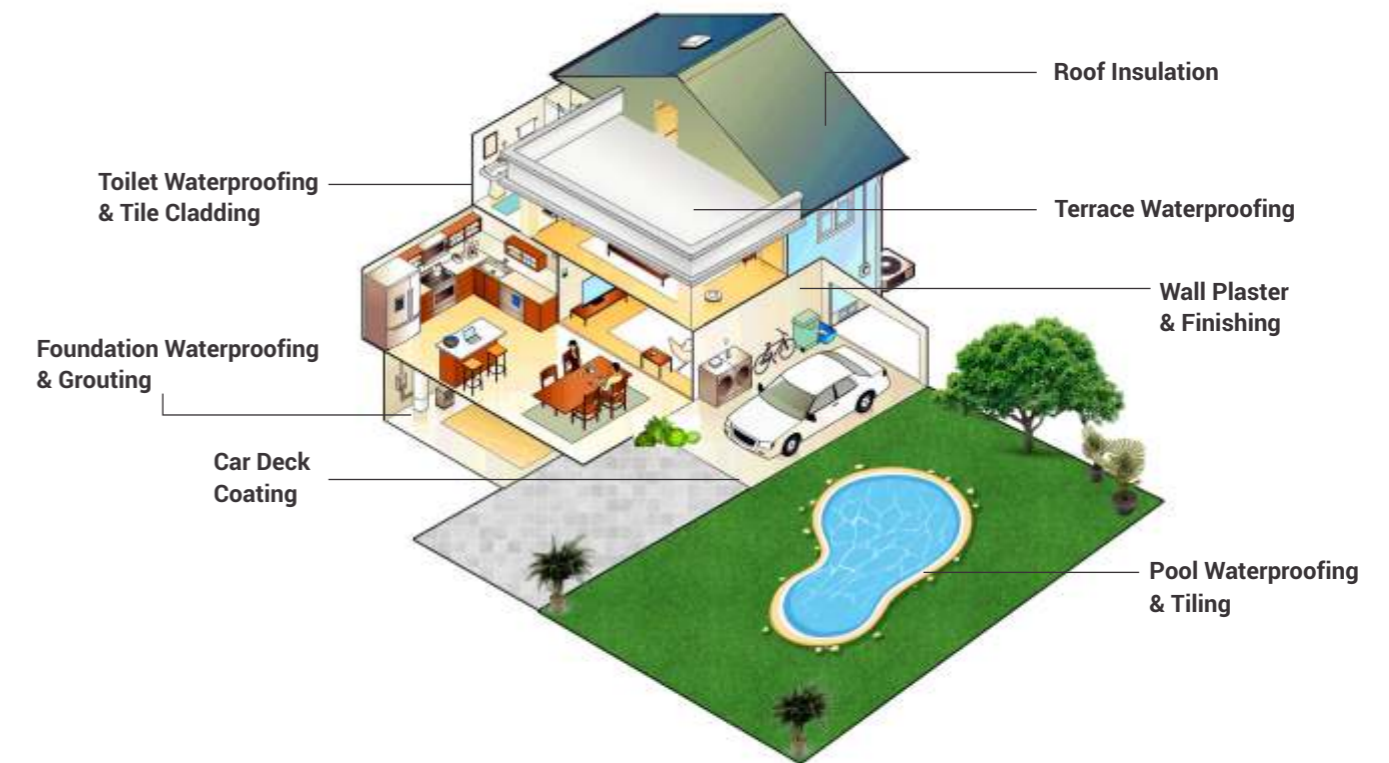

### FLOORING

**BRONCO® CEMCON FLOOR TOP :** Dry shake non-metallic abrasion resistant floor hardener

**BRONCO® FLOOR TOP (M):** Pre-mixed ready-to-use metallic dry shake floor hardener

**BRONCO® CEMSHIELD EF (SL) - PRIMER:** Solvent free epoxy resin based penetrating primer

**BRONCO® CEMSHIELD EF (SL) -** Solvent free self-levelling epoxy floor coating system

### TILE & STONE ADHESIVE

**BRONCO® CEMSHIELD ETA:** Solvent free, thixotropic, two component epoxy adhesive formulate for bonding heavy duty marble, granite slab etc.

**BRONCO® DURA FLEX:** Pre mixed water resistant cementitious polymer modified multipurpose tile adhesive

**BRONCO® DURA FIRM:** White cement based, high polymer modified tile/stone adhesive

**BRONCO® CEMSHIELD EBA -** High strength non sag epoxy bonding agent

## TECHNICAL MORTARS & GROUTS

### BRONCO® CEMREPAIR PMC



**DESCRIPTION:** BRONCO® CEMREPAIR PMC is a single component cementitious, polymer modified non-reactive selective fibre reinforced repair mortar to provide excellent properties as well as resistance to corrosion and carbonation and shrinkage cracking. BRONCO® CEMREPAIR PMC can be applied in thickness from 10 mm to 50 mm in vertical and 25 mm to 30mm in overhead situation.

**ADVANTAGES:**

- Controlled expansion to ensure positive surface contact
- Chloride free and non - metallic hence no rusting or staining on exposed edges
- Excellent bond to the concrete and steel substrate
- Extremely low permeability provides maximum protection against corrosion and carbonation.
- Ready to use - only addition of water is needed at site.
- Suitable to apply by hand trowel or by special mortar spray machine

**USES:** Structural and cosmetic repairs

**PACKING:** 25 Kg Laminated BOPP Bag

### BRONCO® CEMREPAIR MC

**DESCRIPTION:** BRONCO® CEMREPAIR MC is ready to use, cementitious micro concrete. The material is based on cements, graded aggregates, fillers and additives which improve controlled expansion of mortar and minimize water demand, thus ensuring high early and ultimate strength and long term durability.

**ADVANTAGES:**

- Controlled expansion to ensure positive surface contact
- Quickly develops high compressive strength to facilitate early reinstatement
- High ultimate strength and low permeability
- Chloride free and non-metallic hence no rusting or staining on exposed edges
- Pre mixed, addition of water only needed
- Easy to pour due to its free flowing and self-levelling nature, can be pumped or poured into restricted locations
- Excellent bond strength
- Excellent plasticity during placement and requires no vibrations



**USES :** Repair of damage concrete like Columns, Beams, and Slabs. Facilitates early commissioning of equipment subject to high vibration and high early and ultimate strength

**PACKING :** 25Kg Laminated BOPP Bag

### BRONCO® CEMGROUT POXY 21ULV

**DESCRIPTION:** BRONCO® CEMGROUT POXY 21ULV is a two component (Component A – Resin, and Component B - Hardener) solvent free ultra - low viscosity free flowing, fast curing epoxy resin system.

**ADVANTAGES:**

- Designed especially for pressure injection into concrete for carrying out structural repairs.
- Due to its ultra-low viscosity, it can be injected into extremely fine cracks also.
- The cured resin possesses high mechanical strength, excellent adhesion, practically no shrinkage and chemical resistance.
- Fine cracks, joints and small voids can be successfully sealed with CEMGROUT POXY 21ULV.

**USE :** Dry concrete, mortar, stone, steel and wood, columns, beams, foundations, walls, floors and water retaining structures, penetrating concrete surface sealer for dust proofing.

**PACKING :** 5Kg. Pack- A (Resin): 4Kg, Pack-B (Hardener): 1Kg



### BRONCO® CEMGROUT POXY 80 HES

**DESCRIPTION:** BRONCO® CEMGROUT POXY 80HES is three components solvent free, free flowing and fast curing pourable epoxy grout.

**ADVANTAGES:**

- For carrying out structural repairs it can be filled into concrete/mortar cracks/voids/pockets.
- Can be poured on the steel surface (zinc covered) as backing compound.
- Cured resin possesses high mechanical strength, excellent adhesion, non-shrinking properties and chemical resistance properties.
- Can be used as a sealing material for cracks and voids.
- High strength, the cured material is not brittle and retains a slight flexible nature.
- It is supplied in pre-measured quantities of component-A (Resin), component-B (Hardener) and component-C (Special Aggregate) according to the mixing proportion

**USE :** Fixing of starter bars, Anchors, Fasteners, Tie rods, Crash barrier posts, Fence and Railing posts, Under grouting and bedding of base plates, Machine bases, Seat base plates for light and heavy machinery including heavy impact and vibratory machinery, Reciprocating engines, Compressors, Pumps, Presses, Bridge bearings, Mechanical joints (i.e. road/bridge/deck types, etc.), Sleeper less, direct rail fixing, Crane tracks, Light rail and Permanent way in tunnels, Light rail and Permanent way over bridges.

**PACKING :** 10Kg, 20 Kg kits



### BRONCO® CEMGROUT SP 75

**DESCRIPTION:** BRONCO® CEMGROUT SP75 is a ready to use chloride free blend of dry powder when mixed with clean water, it produces a free flowing, non-shrink high strength grout. The material is based on cement, graded aggregate fillers and additives which imparts controlled expansion of mortar and reduces water demand, thus ensuring positive contact with machine base plate, high early strength and long term durability.

**ADVANTAGES:**

- Controlled expansion to ensure positive surface contact and low water permeability.
- Quickly develops high compressive strength to facilitate early reinstatement.
- High ultimate strength and zero water permeability.
- Chloride and iron free hence no rusting or staining on exposed edges.
- Pre-mixed, addition of water is only needed.
- Easy to pour free flowing and self-levelling nature;
- It can be pumped or poured into restricted locations

**USE :** Anchoring for diaphragm wall, Machine and steel column foundation, Anchorage of bolt and steel bar, Base plate grouting of cold as well as hot rolling mills in steel plants. Grouting of bearing pads, Grouting of heavy turbines base etc.



**PACKING :** 25Kg Laminated BOPP Bag



**USE :** Grouting of machine base plates, column bases, anchor bolts, bridge bearings, high vibration and requiring high early strength

**PACKING :** 25Kg Laminated BOPP Bag

### BRONCO® CEMGROUT GP 80

**DESCRIPTION:** BRONCO® CEMGROUT GP80 is a chloride free; cement based free flowing, very high ultimate strength, non-metallic, non-shrink grout. The material is based on cements, graded aggregates, some special polymers and additives which impart controlled expansion of mortar and minimizes water demand, thus ensuring high compressive strength and long term durability.

**ADVANTAGES:**

- A consistent continually controlled mixture
- Eliminates shrinkage, has flowable consistency, good workability and excellent void filling action (self-levelling).
- Ready to use and allows ample time for finishing work.
- Can be poured, poked, pumped, dry packed and rammed
- Cement coloured and non staining
- Can be pumped through small nozzles over great distances
- Contains no harmful chemicals

# WATERPROOFING

## BRONCO® CEMSHIELD PU 1K

**DESCRIPTION:** BRONCO® CEMSHIELD PU 1K is a single component; liquid applied pure polyurethane based, elastomeric coating for waterproofing.

**ADVANTAGES :**

- High elasticity and flexibility
- Excellent adhesion to concrete and mortar.
- Fully bonded system & tar free
- Root resistant & easy to apply.
- Excellent crack bridging capacity even at low temperatures.
- Monolithic – no laps, welds or seams.
- High water vapour permeability - low risk of blistering.
- Resistant to standing water

**USE :** Applicable for outdoor use, concrete and cement mortar, waterproofing of roofs, balconies and terraces, podium, garden etc.

**PACKING :** 18/20 Kg Pails



## BRONCO® CEMGUARD KRYL

**DESCRIPTION:** BRONCO® CEMGUARD KRYL is acrylic polymer based elastomeric, waterproofing protective coating system. In addition to UV resistance acrylic polymer, BRONCO® CEMGUARD KRYL is designed with proprietary additives to resist post growth of algae and fungus. The thixotropic nature of the coating helps to apply thick film to get desired film thickness (1 to 1.5mm) with minimum no of coats.

**ADVANTAGES :**

- Easy application; can be applied by brush, roller and squeegee at site.
- Elastomeric in nature; up to 2 mm crack bridging capacity.
- UV Resistance- does not yellow in sun rays exposure.
- Excellent resistance to carbon dioxide, acid rain, and alkali solution.
- Desired high tensile strength can be achieved by providing single / multilayer glass fibre cloth.
- Excellent resistance to dirt pick up.
- No VOC (Volatile Organic Compound).

**USE :** Old as well as new flat roof / slope concrete roof/ terrace/ podium, brick bat coba, concrete screed old acrylic coating, waterproofing / protective coating of metal/ asbestos sheet roof.

**PACKING :** 20 Kg Plastic Bucket



## BRONCO® CEMGUARD PLUS

**DESCRIPTION:** BRONCO® CEMGUARD PLUS is a two component acrylic polymer modified cementitious coating which consists of BRONCO® CEMGUARD PLUS powder and BRONCO® CEMGUARD PLUS acrylic emulsion.

**ADVANTAGES :**

- Excellent barrier to carbon dioxide, chloride and sulphate ions.
- Allows water vapour to escape from the structure.
- Waterproof-suitable for water retaining structures.
- High resistance to the effect of long-term weathering, durable in all climate conditions including UV attack.
- Nontoxic - ideal for potable water tanks.
- Flexible with thermal expansion similar to concrete.
- Excellent bond to concrete and masonry.
- Good crack accommodation capacity.
- Minimum surface preparation needed and low labour costs

**USE :** All types of structures, concrete, brick and block work substrates, masonry surfaces and bridge, water tanks, reservoirs, drainage culverts basements and roofs, shrinkage cracks

**PACKING :** 12 Kg Laminated Box

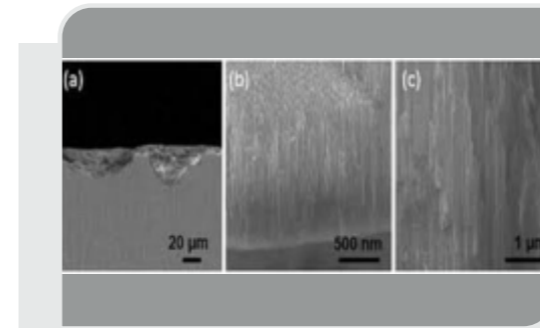

**Uses :** Concrete foundations, walls, and slabs on grade. Marine structures, elevator pits and equipment pits. Parking structures, swimming pools and water features. Water towers, reservoirs and storage tanks. Tunnels, pipes and underground vaults. Water treatment reservoirs, bridge decks. Elevated slabs and ramps, rooftops and roof decks

**PACKING :** 25Kg Laminated BOPP Bag

## BRONCO® CEMGUARD THERMOKRYL

**DESCRIPTION:** BRONCO® CEMGUARD THERMOKRYL is pure acrylic polymer based elastomeric high build solar heat reflecting eco - friendly emulsion for roof and exterior walls.

**ADVANTAGES :**

- Easy application
- Elastomeric in nature; up to 1 mm crack bridging capacity
- UV resistance- does not yellow in sun rays exposure
- Excellent resistance to carbon dioxide, acid rain and alkali solution
- Reduces cooling and heating demand
- Save energy and utility costs by maintaining temperature inside the room
- Excellent resistance to dirt pick up
- No VOC (Volatile Organic Compound)
- Can be tinted with good quality water based color fast pigment paste
- Excellent adhesion with most building material including concrete, metal and wood



**USE :** Roof, basements, rafts, against rising dampness, retaining structures, water bodies, reservoirs, balconies, bathrooms, sunken areas, fountains, dome structures, decks and terraces.

**PACKING :** 15 Kg Laminated Box

## BRONCO® CEMCRYSTAL PLUS

**DESCRIPTION:** BRONCO® CEMCRYSTAL PLUS Waterproofing System is a surface-applied crystalline slurry treatment that transforms new or existing concrete into a permanent waterproof barrier. BRONCO® CEMCRYSTAL PLUS Waterproofing System lowers the permeability of concrete and protects against the ingress of water and waterborne chemicals.

**ADVANTAGES :**

- Replaces unreliable exterior membranes, liners and coatings
- Reaches well below the surface and is not affected by surface wear or abrasion
- Self-seals hairline cracks up to 0.5 mm.
- Reactivates in the presence of moisture
- Effective against hydrostatic pressure up to 145 m (476 ft.) of head pressure
- Waterproofing increases with time & waterproofs from any direction (i.e. positive or negative side)
- Treatment may be applied to old or new concrete
- Safe for contact with potable water.
- Permanently waterproofs the concrete
- Increases reliability and quality control & lowers the cost of waterproofing
- Increased durability decreases building maintenance and repair costs
- Impervious to physical damage and deterioration
- Protects reinforcing steel against corrosion
- Superior performance enhancing your reputation for high quality work



**USES :** Heat insulation and waterproofing of old as well as new flat / slope concrete /metal roof, terrace and walls of residential, commercial and industrial buildings.

**PACKING :** 20 Kg Plastic Bucket

## BRONCO® CEMGUARD

**DESCRIPTION:** BRONCO® CEMGUARD is a two component acrylic modified cementitious coating applied by brush, roller or trowel to waterproof and resurface concrete, masonry and most other construction materials. BRONCO® CEMGUARD provides an effective barrier to waterborne salts and atmospheric gases. Fluid applied BRONCO® CEMGUARD provides a hard wearing, seamless, waterproof membrane for roofs and foundation protection.

**ADVANTAGES:**

- Resistant to UV (Ultra - Violet) rays
- Develops excellent bond with most of the building materials.
- Prevents peeling and blistering
- Arrests salt petrel and prevent penetration of salts into concrete and mortar.
- Unaffected by chemical attacks ranging from mild acids and strong alkalis.
- Highly durable in continuous wet service condition.
- One time application, properties improve with age.
- Versatile product

## READYMIX MORTAR



### BRONCO® MASTER PLAST

**DESCRIPTION:** BRONCO® MASTER PLAST is a polymer modified; fiber reinforced premixed cement based plaster. It can be used on interior and exterior wall surface. It is convenient, easy to use, stronger and bonds better to its substrate. Provides an even surface on which tiling can be done faster and efficiently.

**ADVANTAGES:**

- High Strength
- Cracks free wall
- Faster application
- Excellent coverage
- Economical
- Premixed

**USE:** Brick surface, Stone wall, AAC block / Concrete block surface, Concrete surface

**PACKING:** 40 Kg Laminated BOPP Bag

### BRONCO® MASTER PLAST S

**DESCRIPTION:** BRONCO® MASTER PLAST S is cement based plastering/rendering material composed of hydraulic binders, selected natural sand, aggregates, and special additives. It is supplied as a dry powder in bags/bulk ready to use on site, which requires only addition of clean water to produce cohesive mortar.

BRONCO MASTER PLAST S is specially designed for application by spray machine and it can be used manually if required and contains special shrinkage control additive and provides good adhesion with uniform colour surface.

**ADVANTAGES:**

- Fast mixing application using spray machine.
- Contains special additive that reduces friction and prolongs lifespan of equipment.
- Factory controlled pre-blend ensures consistent high quality.
- Requires only addition of water on-site at the time of usage.
- Uniform colour/mass. Improved workability & curing.
- Easy application with uniform work flow enables high productivity & superior finishing.
- Strong adhesion on variety of substrates.
- Internal & external applications.
- Shrinkage control reduces surface cracks.
- Suitable for humid & dry conditions.



**USE:** Internal & external surface applications. it can be used in bricks, blocks, stone walls as well as concrete surface.

**PACKING:** 40 Kg Laminated BOPP Bag

### BRONCO® MASTER PLAST FP

**DESCRIPTION:** BRONCO® MASTER PLAST FP is cement based plastering material composed of hydraulic binders, natural sand, selected graded aggregates, special fibers and special additives. It is supplied as a dry powder in bags/bulk ready to use on site, which requires only the addition of clean water to produce cohesive mortar. BRONCO® MASTER PLAST FP is specially designed for application by spray machine and it can be used manually if required and contains special shrinkage control additive and provides good adhesion with uniform color surface. BRONCO® MASTER PLAST FP can be applied at thicknesses ranging from 10mm to 25mm.

**ADVANTAGES:**

- Fast mixing application using spray machine.
- Contains special additive that reduces friction and prolongs lifespan of equipment.
- Factory controlled pre-blend ensures consistent high quality.
- Requires only addition of water on-site at the time of usage.
- Uniform color/mass.
- Improved workability & curing.
- Easy application with uniform work flow enables high productivity & superior finishing.
- Strong adhesion on variety of substrates
- Internal & external applications.
- Shrinkage control reduces surface cracks.
- Suitable for humid & dry conditions.



**USE:** Strong adhesion on variety of substrates Internal & external applications

**PACKING:** 25 Kg Laminated BOPP Bag

## TILES & STRUCTURAL ADHESIVES

### BRONCO® CEMSHIELD ETA

**DESCRIPTION:** BRONCO® CEMSHIELD ETA is a solvent free thixotropic, two part epoxy adhesive especially formulated for bonding heavy duty ceramic tiles, marble, granite slabs etc. on concrete/masonry substrates.

**ADVANTAGES:**

- High bond strength.
- Non slump
- No primer required
- High initial and ultimate strengths.
- Impermeable to liquids and water vapour
- Chemical resistant and water resistant
- Suitable for dry and slightly damp concrete surfaces (Moisture tolerant)
- Hardening is not affected by humidity
- Thixotropic: non sag in vertical and overhead applications
- Solvent free and chemical resistant
- Hardens without shrinkage
- Different coloured parts (for mixing control)



**USES:** Vertical surface like walls, tank linings, Horizontal surface like floorings, basements, roofs, sloped, Inclined surfaces like sloped roofs etc.

**PACKING:** 3 Kg Kit

### BRONCO® CEMSHIELD EBA

**DESCRIPTION:** BRONCO® CEMSHIELD EBA is a fast curing, two component specially designed Epoxy Adhesive material for bonding. It hardens in few hours. It is a solvent free thixotropic high strength compound. It is used as general purpose adhesive for many applications conforming to ASTM C 881.

**ADVANTAGES:**

- High initial and ultimate strengths.
- Impermeable to liquids and water vapour
- Suitable for dry and slight damp concrete surfaces
- Hardening is not affected by humidity
- Thixotropic: non-sag in vertical and overhead applications
- Solvent free
- Hardens without shrinkage
- Different coloured parts (for homogeneous mixing).



**USES:** TPE based expansion joint tape, groove & crack filling on vertical surface as well as overhead surface, spout sealing, expansion joint bonding, Metal to metal, Metal to wood, Concrete to metal, Concrete to wood etc.

**PACKING:** 3 Kg Kit

### BRONCO® DURA FIRM

**DESCRIPTION:** BRONCO® DURA FIRM is a high polymer modified, white cement based tile adhesive suitable for fixing wall and floor tile & natural stone in interior and exterior situations up to 6 mm bed thickness (can be extended up to 12 mm in area of limited extent).

**ADVANTAGES:**

- Can be used on damp substrates.
- Offers high adhesive bond strength.
- Excellent slip resistance.
- High early strength.
- Fast curing.
- Water resistant.
- Long open wet time (upto 30 minutes).
- Thixotropic property.
- Tropicalized and eco friendly, offers no health hazards to users.
- Economical



**USE:** Wall and floor tiles, mosaics, vitrified and fully vitrified tiles, marble, terrazzo and natural stone

**PACKING:** 25 Kg Laminated BOPP Bag



## BRONCO® DURA FLEX

**DESCRIPTION:** BRONCO® DURA FLEX is a ready-to-use, thin or thick bed, water resistant, pre-mixed single component, cementitious polymer modified high strength tile adhesive in powder form.

### ADVANTAGES :

- Can be used on damp substrates.
- Offers high adhesive bond strength.
- Excellent slip resistance.
- High early strength.
- Fast curing.
- Water resistant.
- Long open wet time (upto 30 minutes).
- Thixotropic property.
- Tropicalized and eco friendly, offers no health hazards to users.
- Economical

**USE:** Fixing Ceramic, Vitrified, Mosaic, Marble and Granite Tiles

**PACKING :** 25 Kg Laminated BOPP Bag

## BRONCO® DURA NSA

**DESCRIPTION:** BRONCO® DURA NSA is a ready-to-use, thin or thick bed, water resistant, premixed single component, cementitious polymer modified multipurpose tile adhesive in powder form.

### ADVANTAGES :

- Can be used on damp substrates
- Offers high adhesive bond strength
- Excellent slip resistance
- High early strength
- Fast curing
- Water resistant
- Long open wet time
- Thixotropic property (Economical.)

**USE:** Bonding Ceramic, Vitrified tiles to concrete surfaces floors and walls. It can also be used for fixing Aerated Autoclave Lightweight Concrete blocks (AAC) or CLC blocks.

**PACKING :** 25 Kg Laminated BOPP Bag



## BRONCO® BLOCK BOND

**DESCRIPTION:** BRONCO® BLOCK BOND is ready to use grey cement based non-shrink, self-curing, water resistance mortar for fixing AAC blocks, Concrete blocks, Fly ash bricks, Precast panels etc.

### ADVANTAGES :

- Ready to use, only water to be added.
- Thinner jointing material with very high tensile adhesion strength improving the overall masonry strength.
- Better bond than conventional cement based mortar
- Faster to apply due to good spreadable properties.
- Excellent high strength & water retention properties
- Economical as quantity of mortar is less than conventional mortar
- Self-curing

**USE :** Fixing Precast panels and jointing masonry units like AAC blocks, Concrete blocks, Fly ash bricks etc.

**PACKING :** 40 Kg Laminated BOPP Bag



## SEALANTS



## BRONCO® CEMSHIELD PS

**DESCRIPTION:** BRONCO® CEMSHIELD PS is a two component fuel resistant elastomeric joint sealant based on liquid Polysulphide resin and catalyst. When these two components are mixed, a flexible solid elastomeric rubber is formed. The cured sealant exhibits excellent adhesion to most of building materials and superior movement accommodation as compared to conventional sealing compounds like bitumen, asphalt mastic, etc. BRONCO® CEMSHIELD PS is available in gun grade and pour grade.

### ADVANTAGES :

- Excellent adhesion to most building materials including aluminium, concrete, marble, stone, brick, masonry block, quarry tiles, timber etc.
- Forms a tough elastic rubber like seal
- Resilient, recovers the original width after expansion and contraction without losing the surface bond.
- Resistant to water, UV rays, oxidation, corrosive fumes, motor and aviation fuels, dilute acids and alkalis.
- Excellent performance in wide service temperature range from -20 C to +80 C

**USES :** Parking lots, concrete pavements, runways, Extreme temperature zones, Sealing of expansion and construction joints of concrete, Sealing of dynamic cracks, Glazing joints of doors and window frames, curtain walls, etc.

**PACKING :** 4 X 4 Kg kit = 16 Kgs Laminated Box

## BRONCO® CEMSHIELD PS (SPL)

**DESCRIPTION:** BRONCO® Cemshield PS (SPL) is a high performance, self-levelling, chemical resistant elastomeric joint system. Due to its high polysulphide polymer content, it is resistant to many chemicals, shrinkage, aging, thermal stress and the effects of outdoor exposure. It is highly resilient and has excellent recovery characteristic after extended period of compression or elongation.

### ADVANTAGES :

- It is highly resilient and has excellent recovery characteristic after extended period of compression or elongation
- Resistant to many chemicals, shrinkage, aging, thermal stress and the effects of outdoor exposure

**USE :** Concrete roads and highways, Rigid pavements in airports, Potable water retaining structure, Floor joints in building, Bridges

**PACKING :** 4 x 4 Kg in a carton and 4 x 6 Kg in a carton



## BRONCO® CEMSHIELD PU(S)

**DESCRIPTION:** BRONCO® CEMSHIELD PU(S) is a single pack polyurethane sealant for horizontal (self-levelling, type-S) and for vertical construction (non-sag, type -NS).

### ADVANTAGES :

- Quick initial cure to minimize down time.
- Resistant to wide range of chemicals, water, U.V., oils and solvents.
- Excellent tensile strength and elongation.
- Economical.

**USES :** Metal frame circumference sealing, Various joint sealing of concrete structures, Repairing of cracks, Joint sealing of roads and factory floors.

**PACKING :** 600ml sausage / 310 ml cartridge

## EXPANSION & CONSTRUCTION JOINT SYSTEM

### BRONCO® CEMSHIELD BAND EXP



**DESCRIPTION:** BRONCO® CEMSHIELD BAND EXP is a high performance waterproofing Expansion Joints tape based on functional thermoplastic elastomer for applications of sealing expansion joints and cracks in areas exposed to high water pressure and thermal movement. The product is suitable for outside applications under high physical demands like elasticity, tensile strength, resistance against many chemical substances and other outside influences. The product is fusible with hot air and can bond with BRONCO® CEMSHIELD EBA

**ADVANTAGES:**

- Excellent elasticity accommodates high structural movement
- Very good low temperature flexibility and high temperature stability
- Excellent weather and chemical including wide pH range resistance
- Does not rot.
- Resistance to root penetration.

**USES:** Waterproofing of internal old and new joints of water tanks, reservoirs, swimming pools. Sealing Joints of underwater concrete structures, large concrete decks, car parks, tunnels, roofs, podiums. Repairing and sealing of joints where structural movement is very high, ideal sealing tape where joint is wider than 40mm

**PACKING:** 150 mm x 20 m x 4 Roll, 200 mm x 20 m x 4 Roll, 300 mm x 20 m x 4 Roll

### BRONCO® HYDROSWELL

**DESCRIPTION:** BRONCO® HYDROSWELL is compacted in in-situ concrete or between prefabricated concrete elements will expand in contact with water and in this way fill the voids in the joints. Thanks to its flexibility and swell-capacities, BRONCO® HYDROSWELL can absorb the movements of the construction. The swell-capacities of BRONCO® HYDROSWELL are reversible and infinite. The durability and effectiveness of the system thus largely exceed the lifespan of the construction.

**ADVANTAGES:**

- Expands slowly to ensure non-disturbance of fresh concrete.
- Resilient enough to fill small gaps and difficult profile of concrete.
- Reversible swellability
- Does not corrode in fully immersed condition.

**USES :** Construction and cold joints in concrete, pipe penetrations, sewer systems, subterranean prefabricated concrete elements, temporary openings, etc. Water treatment plants, underground car park, water reservoirs, swimming pools, metro systems and other concrete constructions under relatively high water pressure.

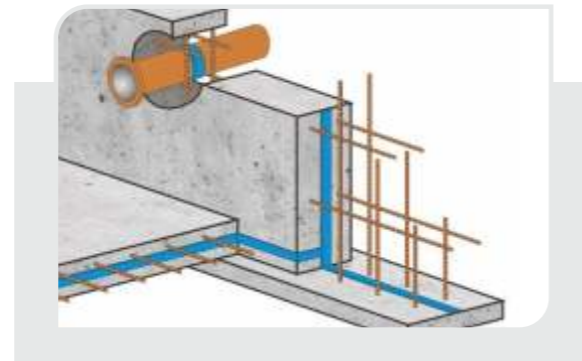

**PACKING :** 20 mm x10 mm, 20 mm x 6 mm sizes are available in packs of 100RMT length.

### BRONCO® HYDROSWELL MASTIC

**DESCRIPTION:** BRONCO® HYDROSWELL MASTIC is an off white gun applied mastic with good adhesion to concrete steel, glass, PVC, HDPE in contact with water, BRONCO® HYDROSWELL MASTIC will expand up to min 250% and provide a durable joint sealant with constant adhesion and expansion features.

**ADVANTAGES:**

- A double sealing action, which combined with its self adhesive property
- Can be placed on damp or uneven surfaces and functions in a wide range of temperatures and ground conditions
- When applied on smooth or uneven surfaces its tack and filling properties produce and initial seal
- It will expand to increase the sealing pressure and prevent water leakage.

**USE :** Sealing joints in cast in place concrete (even on rough surfaces), precast segments (i.e. manholes, box culverts, cable ducts and pipes), around steel H beams, Sealing between rough surfaces (i.e. slurry walls) and concrete slabs, Bonding strip sealants to rough surfaces, Sealing around bolt spacers and void formers

**PACKING :** 310 ml cartridge / 600 ml. sausage

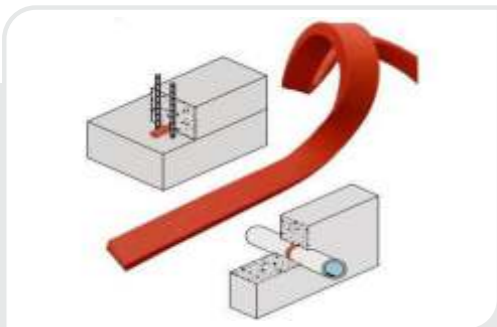

## OUR PRODUCT LIST

Category	Sub – Category	Product Name & Description
Waterproofing	Liquid Applied Membrane	<b>BRONCO® CEMKRETE</b> – Acrylic co -polymer based protective coating & Repairing compound.
		<b>BRONCO® CEMGUARD</b> – Polymer based, elastomeric cementitious waterproofing protective coating system.
		<b>BRONCO® CEMGUARD PLUS</b> – Polymer based highly elastomeric cementitious waterproofing protective coating system.
		<b>BRONCO® CEMCRYSTAL</b> – Surface-applied crystalline slurry treatment that transforms new or existing concrete into a permanent waterproof barrier.
		<b>BRONCO® CEMCRYSTAL PLUS</b> – Surface-applied crystalline slurry treatment that transforms new or existing concrete into a permanent waterproof barrier for both positive and negative side waterproofing
		<b>BRONCO® CEMBOND LATEX</b> – SBR latex based all-purpose waterproofing & bonding compound.
		<b>BRONCO® MARINECOTE</b> – Heavy bodied, polymer based compound for corrosion protection of steel & concrete
		<b>BRONCO® CEMSHIELD PU 1K</b> – Single pack, moisture cured pure polyurethane resin based compound for elastomeric protective coating.
		<b>BRONCO® CEMPRIMER</b> - Heavy bodied – Bitumen based coating & Primer.
		<b>BRONCO® CEMCOAT P</b> - Cold applied heavy bodied bitumen protective coating.
		<b>BRONCO® CEMPRIMER EP</b> - Bitumen modified epoxy primer cum protective coating.
		<b>BRONCO® CEMGUARD KRYL</b> – Acrylic polymer based elastomeric, heavy duty, flexible waterproofing protective coating system.
		<b>BRONCO® CEMGUARD THERMOKRYL</b> - Pure acrylic polymer based elastomeric high build solar heat reflecting waterproofing coating.
		<b>BRONCO® CEMGUARD CTE</b> – Two components high build coal-tar- epoxy specially designed for protection of concrete and steel structure in aggressive environment.
		<b>BRONCO® CEMGUARD 41</b> – High build and fast drying food grade epoxy coating which provides long term protection to cement and concrete substrates.
<b>BRONCO® CEMGUARD EPU</b> - Two part exterior concrete / masonry protective coating based on aliphatic PU resin.		
<b>BRONCO® CEMGUARD ETC</b> - High build epoxy coating for floors and walls for concrete and steel surface.		
Integral		<b>BRONCO® CEMCRYSTAL ADMIXTURE</b> - Low dosage, crystalline waterproofing admixture for concrete & mortars
		<b>BRONCO® CEMKRETE LW +</b> – Low dosage, heavy duty damp proofing agent for concrete and rendering materials.
		<b>BRONCO® CEMKRETE LW</b> – Heavy duty damp proofing agent for concrete and rendering materials.
Preformed Membrane		<b>BRONCO® CEMSHIELD APP</b> – Atactic polypropylene (APP) modified bituminous membrane for Waterproofing
		<b>BRONCO® CEMSHIELD SBS</b> – SBS modified bituminous membrane for Waterproofing.
		<b>BRONCO® CEMSHIELD SBS (SELF)</b> – Self-adhesive polymer modified bituminous membrane for waterproofing.
		<b>BRONCO® CEMSHIELD APP (MF)</b> – Atactic polypropylene (app) modified bituminous membrane for waterproofing with mineral finish.
		<b>BRONCO® CEMSHIELD EPDM</b> – Rubber based, single ply prefabricated membrane made of Ethylene- Propylene-Diene ter polymer.
		<b>BRONCO® CEMSHIELD PVC</b> – Geomembrane with twin / single color (twin color for tunnel and basement waterproofing)
		<b>BRONCO® LDPE FILM / SHEET / LINER</b> - Low density polyethylene membrane for basement, tunnel etc waterproofing.
<b>BRONCO® HDPE SHEET</b> - High density polyethylene (HDPE) membrane for basement, tunnel etc. waterproofing.		

# Technical Mortars

Category	Sub – Category	Product Name & Description
Technical Mortars	Cementitious Flooring	BRONCO® CEMCON FLOOR TOP – Ready to use, dry shake non-metallic, abrasion resistant flooring hardener.
		BRONCO® CEMCON FLOOR TOP (M) – Ready to use, dry shake, metallic, high Abrasion resistant and water resistance floor hardener.
		BRONCO® CEMSCREED SLF - Self-levelling underlayment cementitious flooring for internal applications.
	Epoxy Flooring/ Mortar/ Coating	BRONCO® CEMSHIELD EF (SL) PRIMER – Two components fast curing epoxy based primer for epoxy flooring.
		BRONCO® CEMSHIELD EF (SL) – Three components, solvent free fast curing self-levelling epoxy flooring.
	Cementitious Grouts	BRONCO® NSPG – Polymer modified non-shrink admixture for injection cement grouting.
		BRONCO® NSPG 200 - Expanding, non-shrink polymeric waterproof grouting compound
		BRONCO® CEMGROUT GP80 - Ready to use chloride free, non-shrink, free flow, very high strength cementitious grout.
		BRONCO® CEMGROUT SP75 - Ready to use chloride free blend of dry powder when mixed with clean water, it produces a free flowing, non- shrink high strength anchor grout.
		BRONCO® CEMGROUT 60 – Ready to use chloride free non shrink high strength cementitious free flow grout.
	Epoxy Grouts	BRONCO® CEMGROUT POXY21 – Two components, high strength – injectable epoxy grout.
		BRONCO® CEMGROUT POXY21LV – Low viscous two component high strength – injectable epoxy grout.
		BRONCO® CEMGROUT POXY21ULV – Ultra low viscous two component high strength – injectable epoxy grout.
		BRONCO® CEMGROUT POXY 80HES - Three components solvent free, free flowing, and fast curing pourable epoxy grout.
	Repair & Rehabilitation	BRONCO® CEMREPAIR PMC - Single component cementitious, polymer modified non-reactive selective fiber reinforced concrete repair mortar.
		BRONCO® CEMREPAIR MC- Single component, cementitious, high strength pre-mixed flow able micro concrete.
		BRONCO® CEMREPAIR MC40 - Single component, cementitious high strength pre-mixed flowable micro concrete
		BRONCO® CEMPU GROUT - Single component, aqua-reactive PU based expanding grouting compound
		BRONCO® RUSTKIL- Fast acting, easy to use, rust and stain remover especially from iron and steel.
		BRONCO® CEMCON XL5451 - Versatile liquid compound for quick setting and rapid hardening of cement and concrete.
		BRONCO® CEMGUARD ZRP - Two packs, solvent free, epoxy primer enriched with metallic zinc
BRONCO® CEMSHIELD BA - Solvent free epoxy resin based thixotropic bonding agent.		
BRONCO® CEMCON MORTAR SLC - Non-shrink high strength ready to use cementitious self- compacting mortar/ concrete.		
BRONCO® CRACK SEAL - Single part, non- shrinks, cementitious, polymer modified, crack sealer for plaster, masonry and concrete		
Sealants	BRONCO® CEMSHIELD PS (GG & PG) - Two components fuel resistant elastomeric joint sealant based on liquid Polysulphide resin and catalyst.	
	BRONCO® CEMSHIELD PU(S) – Single component polyurethane sealant for horizontal & vertical surface.	
	BRONCO® CEMSHIELD PS (SPL) - High performance, self-levelling, chemical resistant elastomeric joint sealant based on liquid Polysulphide resin and catalyst.	

Category	Sub – Category	Product Name & Description	
Adhesive	Plaster & Block Adhesive	BRONCO® MASTER PLAST - Polymer modified; fiber reinforced premixed cement based plaster/ mortar	
		BRONCO® MASTER PLAST S – High early strength polymer modified, cement based ready mix sprayable plaster.	
		BRONCO® MASTER PLAST FP – High early strength polymer modified, cementitious premixed spray plaster/ render	
		BRONCO® BLOCK BOND - Ready to use, polymer modified, cement based non-shrink, self- curing, water resistance adhesive for fixing AAC blocks, concrete blocks, fly ash bricks etc.	
		BRONCO® BLOCK FIX – Ready to use mortar for fixing AAC blocks, concrete blocks & fly ash bricks	
		BRONCO® DURA TILE MORTAR - Ready to use, cementitious, non-shrink, self- curing adhesive for floor tiles fixing.	
	Tile & Stone Adhesive	BRONCO® DURA NSA - Ready to use, thin or thick bed, water resistant, premixed single component, cementitious polymer modified multipurpose tile adhesive	
		BRONCO® DURA FLEX - Ready to use, thin or thick bed, water resistant, pre-mixed single component, cementitious polymer modified high strength adhesive for fixing wall, floor tile & natural stone	
		BRONCO® DURA FIRM - High polymer modified, white cement based adhesive suitable for fixing wall, floor tile & natural stone	
		BRONCO® CEMSHIELD ETA – Solvent free thixotropic, two part epoxy adhesive especially formulated for bonding heavy duty ceramic tiles, marble ,granite slabs etc.	
		BRONCO® CEMSHIELD EBA - Solvent free, fast curing, two component specially designed Epoxy Adhesive material for bonding TPE based expansion joint tape.	
		Expansion & Construction Joint System	BRONCO® CEMSHIELD BAND EXP - High performance waterproofing tape based on functional thermoplastic elastomer for applications of sealing joints and cracks in areas exposed to high water pressure and thermal movement.
			BRONCO® HYDRO SWELL - Hydro-swelling joint sealant for construction joints, cold joints, pipe penetrations, subterranean prefab constructions, etc.
			BRONCO® HYDROSWELL MASTIC- Gun applied mastic with good adhesion to concrete steel, glass, PVC, HDPE in contact with water.
Concrete Admixtures & Curing Compound	BRONCO® CEMCON PC321 - High range new generation pce based super plasticizing admixture for concrete		
	BRONCO® CEMCON PC322 - High range new generation pce based super plasticizing admixture for concrete		
	BRONCO® CEMCON SCCA - High range super plasticizing self compacting concrete		
	BRONCO® CEMCON SP421 - Old generation multi range plasticizer based admixture for concrete		
	BRONCO® CEMCON SPA – Old generation multi range plasticizer based admixture for concrete		
	BRONCO® CEMCON SRA – Solvent / water based formwork and mould release agent.		
	BRONCO® CEMCON CURE W - Curing agent - wax based/water based & white pigmented for concrete surface.		
Others Accessories	BRONCO® INSUL50 - Extruded polystyrene is heavy duty thermal insulation rigid board, energy conserving insulation material.		
	BRONCO® DRAINCELL RD20 - Protective membrane for waterproofing and provides ventilation for concrete slabs which alleviates heat induced stress and cracking.		

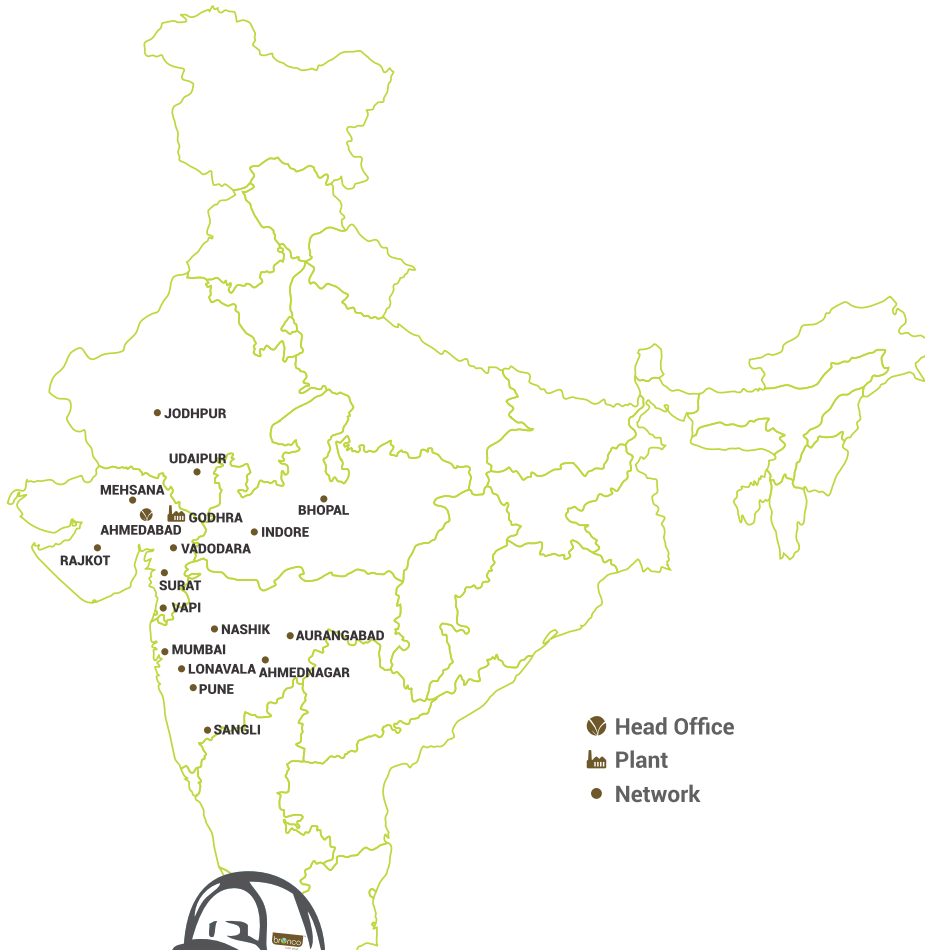

**A Benchmark For Quality Solutions**



**BRONCO BUILDSMART LLP**

215, Symmers Business Park, B/w. Sarkhej-Santipura Cross road,  
 Opp. Hotel Yellow Lime, Sarkhej, Ahmedabad 382210  
 E: info@bronco.in | 079 2979 5685  
 Customer Care : +91 88660 71009